

MINI EFFECT GIMZO X

User's Manual



RJM Music Technology, Inc.

MINI EFFECT GIMZO X

User's Manual

Version 1.0
August 1, 2021

RJM Music Technology, Inc.
2525 Pioneer Ave #1
Vista, CA 92081
E-mail: support@rjmmusic.com
Web: www.rjmmusic.com

Note: This equipment has been tested and found to comply with the limits for a Class B digital device, pursuant to part 15 of the FCC Rules. These limits are designed to provide reasonable protection against harmful interference in a residential installation. This equipment generates, uses and can radiate radio frequency energy and, if not installed and used in accordance with the instructions, may cause harmful interference to radio communications. However, there is no guarantee that interference will not occur in a particular installation. If this equipment does cause harmful interference to radio or television reception, which can be determined by turning the equipment off and on, the user is encouraged to try to correct the interference by one or more of the following measures:

- Reorient or relocate the receiving antenna.
- Increase the separation between the equipment and receiver.
- Connect the equipment into an outlet on a circuit different from that to which the receiver is connected.
- Consult the dealer or an experienced radio/TV technician for help.

Changes or modifications not expressly approved by the party responsible for compliance could void the user's authority to operate the equipment.

Copyright © 2021 RJM Music Technology, Inc. All Rights Reserved.

RJM and the RJM logo are registered trademarks of RJM Music Technology, Inc.
Mini Effect Gizmo X and Mastermind are trademarks of RJM Music Technology, Inc.

TABLE OF CONTENTS

INTRODUCTION	5
FRONT PANEL	6
REAR PANEL	7
CONNECTING MONO AND STEREO DEVICES	9
Mono Connections	9
Stereo Connections	9
Mixing Mono And Stereo Effects	9
Mono In, Stereo Out Effects	10
SPECIAL FEATURES	11
Audio Buffer	11
Built-In Tuner	11
Function Switches	11
Fuzz Mode	12
MIDI USAGE	13
Program Changes	13
Continuous Controllers	14
Bank Selection	15
Loop Order Selection	15
SETUP MODE	17
Selecting MIDI Channel	17
Function Switch Invert	18
Function Switch Momentary	18
Function Switch Grouping	18
Fuzz Mode	19
Mono/Stereo Mode	19
Factory Reset	19
CONNECTING TO A COMPUTER OR TABLET	20
USB Connection	20
Lightning Connection	20
Mini Effect Gizmo Editor	20
EXAMPLE WIRING DIAGRAMS	21
ADVANCED FEATURE: SPLIT MONO MODE	25
SPECIFICATIONS	26

INTRODUCTION

Thank you for purchasing the Mini Effect Gizmo X audio loop switcher! The Mini Effect Gizmo X (aka MEGX) is the latest version of our switching technology that we've been providing to musicians for over 15 years.

The Mini Effect Gizmo X offers 6 stereo-capable loops with programmable loop order. We also include a stereo version of our acclaimed buffer circuit to help preserve your tone, and a TRS function switch jack that allows you to control analog features like amplifier channel switching or tap tempo on a pedal. Full MIDI capability is provided, via standard MIDI connections and USB-C. Editor software is available for PC, Mac and iOS which allows settings backup, firmware upgrades and access to advanced features such as editing loop order and MIDI options.

FRONT PANEL

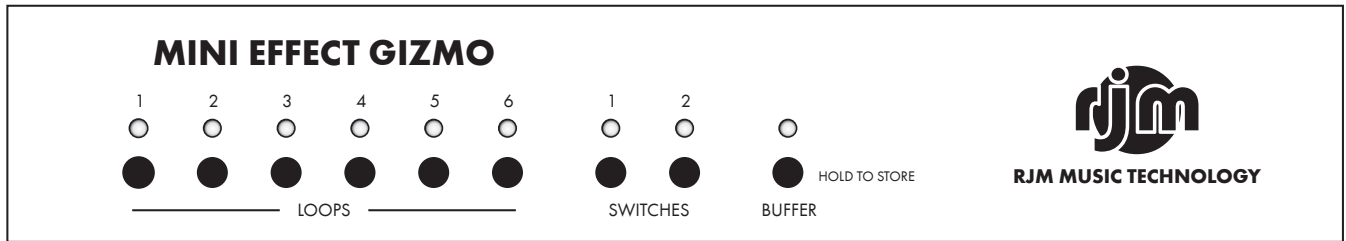

Loops 1 through 6 - These buttons turn audio loops 1 through 6 on and off. Each button lights up to indicate that the corresponding audio loop is active.

Switches 1 and 2 - These buttons turn function switches 1 and 2 on and off. Each button lights up to indicate that the corresponding function switch is active. Refer to the [Function Switches](#) section for more details.

Buffer - When pressed briefly, this button will turn the input buffer on and off. The LED is green when the buffer is on and yellow when it's off. When held down for 3 seconds, this button stores the current state of all switches to non-volatile memory. The buttons will flash to confirm that the state has been stored.

Please note that the store function doesn't work until a preset has been selected from a MIDI controller. If the LEDs don't flash after holding for 3 seconds, that means that either your MIDI connection isn't correct, your MIDI channels are not set correctly, or your MIDI controller isn't sending a Program Change message.

REAR PANEL

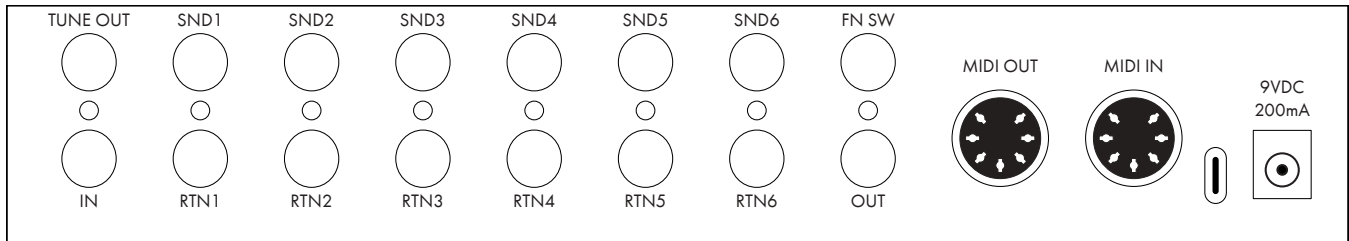

Tune Out - This output is designed to connect to an external tuner. The output is driven by the internal buffer, before it goes through any of the loops. If the tuner output is active, the buffer will also be activated.

In – This is the Mini Effect Gizmo X’s main input. Your guitar is typically plugged in here. Plugging into this jack sends your guitar signal through the buffer and then on to the audio loops. See the [Special Features](#) section for more information on the audio buffer.

Snd / Rtn 1 - 6 – These are the send and return jacks for each audio loop. Connect your effect input to the SND (send) jack and the effect output to the RTN (return) jack. When a loop is active, the audio signal from the previous loop is present at the send jack, and the signal coming in to the return jack is passed on to the next loop. When a loop is turned off, the audio signal bypasses the send and return jacks and the send jack is grounded.

Fn Sw - This is the function switch output. This TRS jack has two relays that short to ground, simulating a typical footswitch. You can use this to control amp channel switching or other devices that take a basic 1 or 2 button momentary or latching footswitch. Refer to the [Function Switches](#) section for more details.

Out – This is the main output from the six loops. Typically, this jack is connected to your amp’s input.

MIDI Out – All incoming MIDI commands are passed back out through this jack. The next MIDI device in your chain (if any) is connected here. A standard 5-pin MIDI cable is typically used here, but a 7-pin MIDI cable can be used to pass phantom power to a connected MIDI device (if the connected device supports phantom power).

MIDI In – Jack for incoming MIDI commands. Connect your MIDI foot controller here using a 5-pin or 7-pin MIDI cable. The Mini Effect Gizmo X will phantom power a compatible MIDI controller if you use a 7-pin MIDI cable. The AC adapter provided with the Mini Effect Gizmo can phantom power most MIDI controllers, provided the controller requires no more than 800mA of current. **Note:** When using with a Mastermind GT, plug the Mastermind GT’s power supply into the Mini Effect Gizmo’s power input. You can then safely phantom power the Mastermind GT using a 7-pin MIDI cable.

USB C - This jack allows you to connect to a Mac, PC, phone or tablet. The Mini Effect Gizmo X is a class compliant device, which means that it needs no driver software and it will appear as a MIDI device in any compatible app.

The MEGX can receive power through its USB C jack, but this is sufficient only for working with the editor software. The audio circuitry won’t function if power is only coming in through USB. Connect a DC power

supply to the MEGX for normal operation. It's safe to connect both USB and a DC power supply to the MEGX at the same time.

Power – This unit requires power supply of 9 to 12 volts DC. The plug should be a 5.5mm/2.1mm barrel connector, similar to those used in most effects pedals. The Mini Effect Gizmo X requires a minimum of 200mA of current, and either polarity is acceptable.

CONNECTING MONO AND STEREO DEVICES

The Mini Effect Gizmo X is capable of switching mono or stereo effects. Its input, output and loops can be all mono, all stereo or a combination thereof. The only audio feature of the MEGX that's always mono is the tuner output.

MONO CONNECTIONS

Mono connections are made as they are with any other typical guitar equipment, using 1/4-inch TS (tip-sleeve) connectors. The MEGX is set to all mono right out of the box, so you can connect a typical setup of guitar, amp and pedals with no settings changes required.

STEREO CONNECTIONS

If you have stereo effects, you can configure your input, output and loops to be stereo using the [Mono/Stereo Mode](#) setting in [Setup Mode](#).

Stereo connections are done using the same jacks as mono connections, but you need to use 1/4-inch TRS (tip-ring-sleeve) connectors. These have three conductors to carry left, right and ground signals, and are the type used on headphones.

Most effect pedals and effect processors don't have TRS connectors, so you'll need a cable to adapt from the stereo TRS jack on the Mini Effect Gizmo to the left and right TS jacks on your effect. This type of cable is called an insert cable, and is available from custom cable builders and some music stores. You'll need two of these per stereo pedal (one for input, one for output), and you'll also need one for the input and one for the output of the Mini Effect Gizmo if those are stereo as well.

If you're able to build your own cables, this is how you would wire an insert cable:

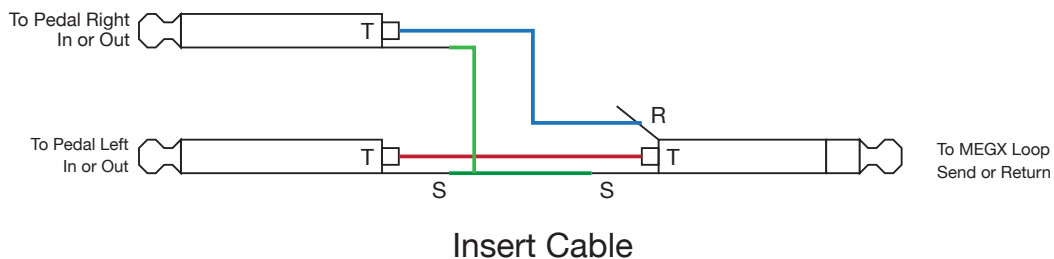

MIXING MONO AND STEREO EFFECTS

You can use configure some loops to be mono and some stereo. This works according to two simple rules:

- If a mono loop is followed by a stereo loop, the mono loop's signal is sent to both the left and right side of the stereo loop.

- If a stereo loop is followed by a mono loop, the left side of the stereo signal is sent to the mono loop.

Typically, you would put all of your mono effects before the stereo effects so that the stereo image is never lost.

MONO IN, STEREO OUT EFFECTS

Some effects have mono inputs and stereo outputs. The Mini Effect Gizmo X editor software can be used to configure a loop this way - it can't be done using the onboard setup mode.

Mono in, stereo out effects work best if you only have one of them (or only turn one on at a time), and they're placed in between your mono and full stereo effects. Any stereo effects placed before a mono in, stereo out pedal will only pass the signal from its left output to the next pedal.

SPECIAL FEATURES

AUDIO BUFFER

Using long cables or many effects may degrade the guitar signal, causing it to lose clarity and definition. The audio buffer is used to “strengthen” the guitar signal and preserve sound quality. The effect may vary from subtle to significant, depending on the length and quality of cables and type of effects used in your rig.

The main input goes through an input buffer before being sent to the switching matrix. The buffer can be turned on or off by pressing the Buffer button on the front panel. If the buffer LED is green, the buffer is on. If it’s yellow, the buffer is off. The buffer can be programmed to turn on or off for each preset, and can be set to automatically turn off when certain loops are active, using [Fuzz Mode](#).

BUILT-IN TUNER

The Mini Effect Gizmo X has an integrated tuner that’s available when used with one of our Mastermind controllers (GT, LT and PBC). The Mini Effect Gizmo X does the actual calculations, and sends the tuner data to the Mastermind to be displayed on its main display.

The Mastermind needs to be running firmware 4.6.1 or later to support this feature. Also, the Mini Effect Gizmo X’s MIDI input needs to be connected directly to the Mastermind’s MIDI output using a 5-pin active MIDI cable (A 5-pin MIDI cable with all 5 pins wired) or 7-pin MIDI cable. There can’t be any other MIDI devices in between the MEGX and Mastermind. Also, bidirectional MIDI needs to be turned on in the Mastermind’s MIDI settings (applies only to the Mastermind GT and Mastermind PBC/10)

FUNCTION SWITCHES

The Mini Effect Gizmo X has the ability to control footswitchable features on many amps. This could be channel switching, reverb, tremolo, etc - just about anything that’s controlled by a 1/4-inch footswitch jack. The **FN SW** jack is used for this purpose. You can use a standard 1/4-inch mono (TS) cable, a TRS 1/4-inch cable or an insert cable to connect to these jacks:

Mono 1/4-inch cable - a mono or TS cable allows you to control one function on an amp using Function Switch 1. This type of connection is typically used with amps that have single button footswitches.

TRS 1/4 inch cable - a stereo or TRS cable allows you to control two functions on an amp that has a two button footswitch.

Insert cable - an insert cable is a 1/4-inch cable that has a TRS (stereo) connector on one end and two 1/4-inch TS (mono) connectors on the other. This allows you to connect to two 1/4-inch TS switching jacks on the same amp. Some amps - most notably Mesa/Boogies - have multiple switching jacks that would work with this arrangement. **Please note!** Don’t connect the two mono plugs of an insert cable to two different amps or two different pedals - in many cases, this could cause a ground loop or worse electrical problems.

Custom cable - it's possible to make adapter cables that adapt from the MEGX's function switch jack to the proprietary footswitch jack on certain amps. Custom cable builders like [Best-tronics](#) are able to make these cables.

The default settings for each switch are latching and normal (non-inverted). These settings will work with the majority of amps. If your amp has different requirements, you can use [Setup Mode](#) or the Mini Effect Gizmo X editor software to change the function switch settings.

The function switches can also be used to control features on certain pedals. For example, the "Favorite" switch on Strymon pedals or the "Red Remote" switch on JHS pedals.

FUZZ MODE

Certain pedals such as fuzzes, wah pedals and some compressors are designed to have a guitar plugged directly into them, and don't sound as good when there's a buffer between the guitar and effect input.

To avoid this problem, but still retain the benefits of a buffer, we've created fuzz mode. This allows you to tell the Mini Effect Gizmo X that a loop has a fuzz or other buffer-sensitive pedal connected. When that loop is turned on, and is the first active effect in the chain, the buffer will automatically bypass until the loop is no longer the first active effect in the chain. Any or all loops can have fuzz mode enabled. Fuzz mode can be configured using [Setup Mode](#) or the Mini Effect Gizmo X editor software.

MIDI USAGE

PROGRAM CHANGES

The Mini Effect Gizmo X can receive MIDI messages from any MIDI controller. You can store different switch settings for MIDI program numbers 0 through 127 in MIDI banks 0 through 7, for a total of 1024 presets. When a Program Change message is received on the correct channel, the Mini Effect Gizmo will automatically recall the saved settings for the given program number.

To set up for MIDI use, simply connect your MIDI controller to your Mini Effect Gizmo's MIDI In jack. The Mini Effect Gizmo is set for MIDI Channel 1 by default. Either make sure your MIDI controller is set up to transmit commands on Channel 1, or use the Mini Effect Gizmo's setup mode to change which MIDI channel the Mini Effect Gizmo responds to. See the [Setup Mode](#) section for more details.

To save a program setting, perform the following steps:

1. Select a preset on your MIDI controller (this should cause the controller to send a MIDI Program Change message).
2. Using the Mini Effect Gizmo buttons, select the audio loops, function switches and/or buffer you wish to have turn on for this preset.
3. Hold down the **Buffer** button on the Mini Effect Gizmo until the LEDs flash. This should take about 3 seconds.

That's all it takes. You can repeat this for any or all of MIDI program numbers 0 through 1023.

If the lights don't flash after a few seconds of holding down the Write button, it means that your Mini Effect Gizmo did not receive a MIDI Program Change message. Check your MIDI cable connection, and make sure that the MIDI controller and Mini Effect Gizmo are set to the same MIDI channel.

Now that your settings have been saved, you can recall your settings by using your MIDI controller to send a Program Change message again. The Mini Effect Gizmo will call up your saved settings and turn on the desired loops, function switches and buffer whenever it receives a MIDI Program Change message.

CONTINUOUS CONTROLLERS

In addition to supporting MIDI Program Change messages, the Mini Effect Gizmo X supports MIDI Continuous Controller messages. The following Continuous Controllers are supported by default:

Continuous Controller	Value	Function
CC80	0...63 64...127	Loop 1 off Loop 1 on
CC81	0...63 64...127	Loop 2 off Loop 2 on
CC82	0...63 64...127	Loop 3 off Loop 3 on
CC83	0...63 64...127	Loop 4 off Loop 4 on
CC84	0...63 64...127	Loop 5 off Loop 5 on
CC85	0...63 64...127	Loop 6 off Loop 6 on
CC86	0...63 64...127	Loop 7 off ¹ Loop 7 on
CC87	0...63 64...127	Loop 8 off ¹ Loop 8 on
CC88	0...63 64...127	Loop 9 off ¹ Loop 9 on
CC89	0...63 64...127	Loop 10 off ¹ Loop 10 on
CC90	0...63 64...127	Loop 11 off ¹ Loop 11 on
CC91	0...63 64...127	Loop 12 off ¹ Loop 12 on
CC102	0...63 64...127	Function Switch 1 off Function Switch 1 on
CC103	0...63 64...127	Function Switch 2 off Function Switch 2 on
CC110	0...63 64...127	Input off Input on
CC112	0...63 64...127	Output(s) off Output(s) on
CC113	0...63 64...127	Output 1 (left) off Output 1 (left) on
CC114	0...63 64...127	Output 2 (right) off Output 2 (right) on
CC115	0...63 64...127	Output 1 (left) on, output 2 (right) off Output 1 (left) off, output 2 (right) on
CC116	0...63 64...127	Tuner output off Tuner output on
CC117	0...63 64...127	Buffer off Buffer on
CC119	0...63 64...127	Internal tuner off Internal tuner on

Note 1: Loops 7-12 only available when using the [Split Mono](#) feature

Any of these CC number assignments can be changed using the Mini Effect Gizmo X editor.

BANK SELECTION

MIDI only allows for 128 unique program numbers. To get around this limitation, MIDI banks are used. To select a preset beyond the 128 limit, you first send a bank select message, then a program change.

The Mini Effect Gizmo can store presets in MIDI banks 0 through 7, for a total of 1024 presets divided over eight banks. Continuous Controller #0 (Bank MSB) is used to select the current MIDI bank, although the Mini Effect Gizmo X editor can be used to change which CC number is used for bank selection. Bank numbers above bank 7 are ignored.

This is how a preset number is calculated:

$$\text{preset number} = (\text{bank number} \times 128) + \text{program change number}$$

Examples:

Bank 0, program 0 = preset 0

Bank 0, program 127 = preset 127

Bank 1, program 0 = preset 128

Bank 1, program 127 = preset 255

Note 1: The MEGX remembers the last bank number received, so if you select a bank, then send only program changes after that, you will remain in the currently selected bank until another bank select message is received.

Note 2: If a loop or other audio feature is assigned the same CC number as bank selection, the audio feature has precedence and bank selection will not be possible until the bank select CC is changed.

LOOP ORDER SELECTION

Loop order can be specified using a MIDI SysEx command. To set the loop order, send the following command to the Mini Effect Gizmo X:

```
F0 00 01 5B <sysex_id> 23 00 <position_1> <position_2> ... F7
```

Where <sysex_id> is the SysEx ID of this unit (default value is 15 hexadecimal). The SysEx ID can be configured using the Mini Effect Gizmo X editor software.

The bytes that follow the command bytes (23 00) are the loop numbers in the order you want them to appear. For example, if you want the loop order to be 4, 6, 3, 2, 1, 5, you would send the following command (assuming the default SysEx ID of 15):

```
F0 00 01 5B 15 23 00 04 06 03 02 01 05 F7
```

If not all loops are specified, they will automatically be added to the end of the loop order, in numerical order.

For example, if you send:

```
F0 00 01 5B 15 23 00 04 02 F7
```

The resulting loop order would be 4, 2, 1, 3, 5, 6, 7, 8, 9, 10, 11, 12

As you can see, the loop order always contains all 12 possible loops (see the [Split Mono Mode](#) section for details on how 12 loops are possible.) Any loops that are turned off or don't exist in your configuration are ignored by the system, but they still need to appear in the loop order.

Because of the way loops are added automatically, you can send an empty loop order to reset the loop order to the default (1 through 12 in numerical order):

```
F0 00 01 5B 15 23 00 F7
```

The current loop order will remain until another loop order SysEx is received, or a PC message is received.

The loop order is not saved unless you hold the Buffer button for 3 seconds, in which case it will be stored to the most recently selected preset.

SETUP MODE

Setup mode allows you to do some basic configuration of the Mini Effect Gizmo X with no computer required. To access all of the configuration options, the Mini Effect Gizmo X editor is also available.

SELECTING MIDI CHANNEL

Configuring the MIDI channel is a very important first step in setting up the Mini Effect Gizmo X. The Mini Effect Gizmo X's channel needs to match the channel that your MIDI controller is sending on. The Mini Effect Gizmo is set by default to send and receive on MIDI Channel 1. To change the send/receive channel:

Hold the Switch 1 button while powering the Mini Effect Gizmo X on. The LEDs on the Mini Effect Gizmo will cycle a few times, then will turn off. The Buffer LED starts flashing at this point. Once that happens, you can release the button. The Switch buttons will now allow you to select the MIDI channel the Mini Effect Gizmo responds to. Use the following chart to select the desired MIDI channel.

MIDI Channel	Switch 1 LED	Switch 2 LED	Switch 3 LED	Switch 4 LED
1	OFF	OFF	OFF	OFF
2	ON	OFF	OFF	OFF
3	OFF	ON	OFF	OFF
4	ON	ON	OFF	OFF
5	OFF	OFF	ON	OFF
6	ON	OFF	ON	OFF
7	OFF	ON	ON	OFF
8	ON	ON	ON	OFF
9	OFF	OFF	OFF	ON
10	ON	OFF	OFF	ON
11	OFF	ON	OFF	ON
12	ON	ON	OFF	ON
13	OFF	OFF	ON	ON
14	ON	OFF	ON	ON
15	OFF	ON	ON	ON
16	ON	ON	ON	ON

Once you've set the MIDI channel and options, press the **Buffer** button. The Mini Effect Gizmo is now in normal operational mode.

FUNCTION SWITCH INVERT

When controlling devices using a function switch, you may find that the thing you're controlling is turned on when the function switch LED is off, and vice-versa, If this is the case, you can invert the function switch to fix the situation.

Hold the Switch 2 button while powering the Mini Effect Gizmo X on. The LEDs on the Mini Effect Gizmo will cycle a few times, then will turn off. The Buffer LED starts flashing at this point. Once that happens, you can release the button. Now, press the Function Switch button or buttons that need to be inverted. Any function switch LED that's on indicates an inverted switch, and an LED that's off indicates a normal (non-inverted) switch.

Once you've set the invert options, press the **Buffer** button. The Mini Effect Gizmo is now in normal operational mode.

FUNCTION SWITCH MOMENTARY

Some devices require momentary switching, where the switch is turned on briefly, then turned off, each time the switch is activated. Normally, the switches are latching, where they turn on or off as needed. Momentary switching is rarely needed, but we've provided the option for those cases where it's necessary.

Hold the Switch 3 button while powering the Mini Effect Gizmo X on. The LEDs on the Mini Effect Gizmo will cycle a few times, then will turn off. The Buffer LED starts flashing at this point. Once that happens, you can release the button. Now, press the Function Switch button or buttons that need to be set to momentary. Any function switch LED that's on indicates a momentary switch, and an LED that's off indicates a normal (latching) switch.

Once you've set the momentary options, press the **Buffer** button. The Mini Effect Gizmo is now in normal operational mode.

FUNCTION SWITCH GROUPING

In some rare cases, function switches need to be grouped, so that turning on one function switch causes the other function switch to turn off. Typically, this is used in conjunction with the momentary setting described above.

Hold the Switch 4 button while powering the Mini Effect Gizmo X on. The LEDs on the Mini Effect Gizmo will cycle a few times, then will turn off. The Buffer LED starts flashing at this point. Once that happens, you can release the button. Now, press the Function Switch button or buttons that need to be set to momentary. Any function switch LED that's on indicates a grouped switch, and an LED that's off indicates a normal (ungrouped) switch.

Once you've set the grouping options, press the **Buffer** button. The Mini Effect Gizmo is now in normal operational mode.

FUZZ MODE

Fuzz Mode lets you specify that certain loops contain pedals that don't work well with buffers, so that the Mini Effect Gizmo X can disable the buffer when the pedal is active and the buffer would interfere with its operation. For more details, please refer to the [Fuzz Mode](#) section.

Hold the Switch 5 button while powering the Mini Effect Gizmo X on. The LEDs on the Mini Effect Gizmo will cycle a few times, then will turn off. The Buffer LED starts flashing at this point. Once that happens, you can release the button. Now, press the Switch button or buttons to enable fuzz mode on loops. If a loop's LED is on, fuzz mode is on for that loop. If the LED is off, fuzz mode is off.

Once you've set the fuzz mode options, press the **Buffer** button. The Mini Effect Gizmo is now in normal operational mode.

MONO/STEREO MODE

You can configure the input, output or loops to be mono or stereo from this mode.

Hold the Switch 6 button while powering the Mini Effect Gizmo X on. The LEDs on the Mini Effect Gizmo will cycle a few times, then will turn off. The Buffer LED starts flashing at this point. Once that happens, you can release the button.

Now, each loop and switch LED indicates a mono or stereo setting:

Loop 1-6 LEDs indicate whether loops 1-6 are mono or stereo

Function Switch 1 LED indicates whether the input is mono or stereo

Function Switch 2 LED indicates whether the output is mono or stereo

In all cases, LED off means the loop, input or output is mono, and LED on means that it's stereo.

Once you've set the mono/stereo mode options, press the **Buffer** button. The Mini Effect Gizmo is now in normal operational mode.

FACTORY RESET

To return the Mini Effect Gizmo X to its factory state, hold the 1 and 4 buttons while you power it up. After a few seconds all of the LEDs should turn on. You can release the buttons at this point. After a few seconds, the LEDs will turn off, leaving the Mini Effect Gizmo in the factory reset state.

CONNECTING TO A COMPUTER OR TABLET

The Mini Effect Gizmo X's USB-C port allows you to connect it to a variety of devices. It's a class compliant MIDI device, meaning that it will work on most computers and tablets without the need to install any driver software. The Mini Effect Gizmo X will appear as a standard MIDI device in MIDI enabled apps.

USB CONNECTION

You can connect the MEGX to any USB host port. Most computers have USB A ports (the long rectangular ones). A USB A to USB C adapter cable is needed to make this connection.

Newer computers, newer iPad Airs and the iPad Pro will have these smaller USB C ports. A USB C cable can be used to connect it directly to the MEGX. Just make sure that the cable is a "charge and sync" cable and not just a charging cable. The latter is used for charging purposes only and doesn't allow communication over the cable. Cables that come with chargers tend to be usable for charging only, but USB C cables purchased individually are typically charge and sync.

LIGHTNING CONNECTION

iPhones and many iPads have Apple's proprietary Lightning connector. You can connect the MEGX to them using a combination of two cables. The first thing you need is Apple's "Lightning to USB Camera Adapter" cable. This adapts the phone's Lightning connector to a USB A port. Then, you need a USB A to USB C cable. With these two cables, you can connect your Mini Effect Gizmo to your iPad, and the MEGX will appear in your MIDI enabled apps.

MINI EFFECT GIZMO EDITOR

The Mini Effect Gizmo X Editor software is available for iPad, MacOS and Windows systems and is used to do deep editing of a connected Mini Effect Gizmo X. This app allows you to do more advanced editing, including naming presets, changing loop order, locking loops on or off and editing MIDI parameters.

You can find this app on our [website](#).



RJM Music Technology, Inc.
www.rjmmusic.com

Mini Effect Gizmo X Wiring Diagram

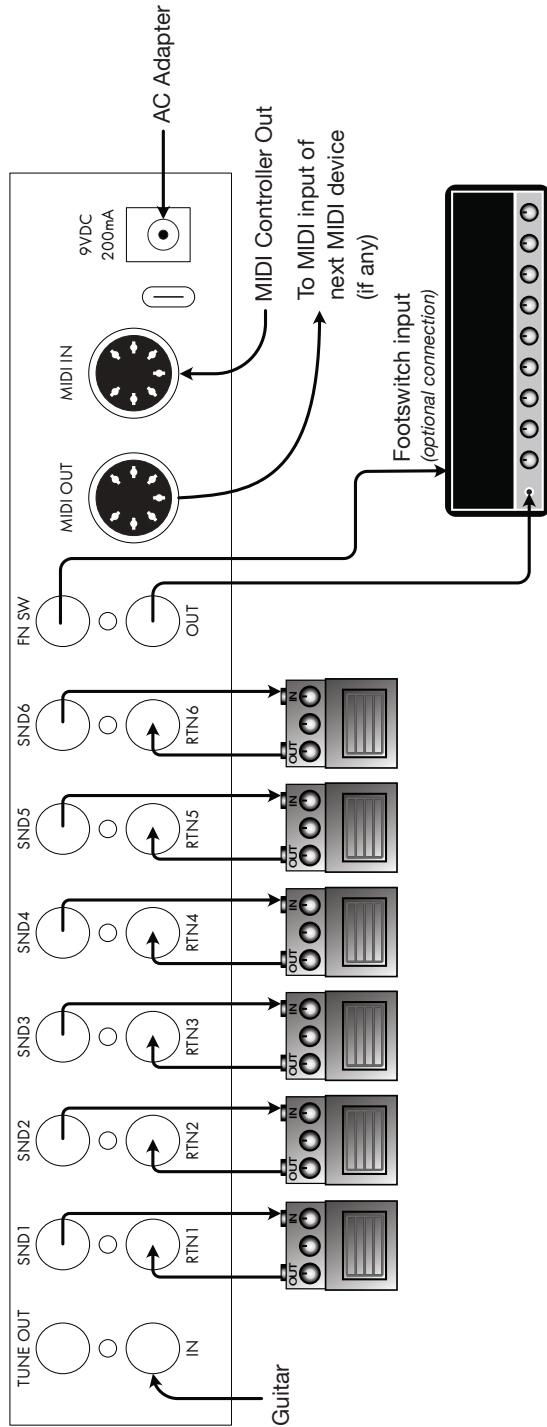

6 pedals in front of amp

This is the simplest connection method, 6 pedals wired in front of an amp's input.



RJM Music Technology, Inc.
www.rjmmusic.com

Mini Effect Gizmo X Wiring Diagram

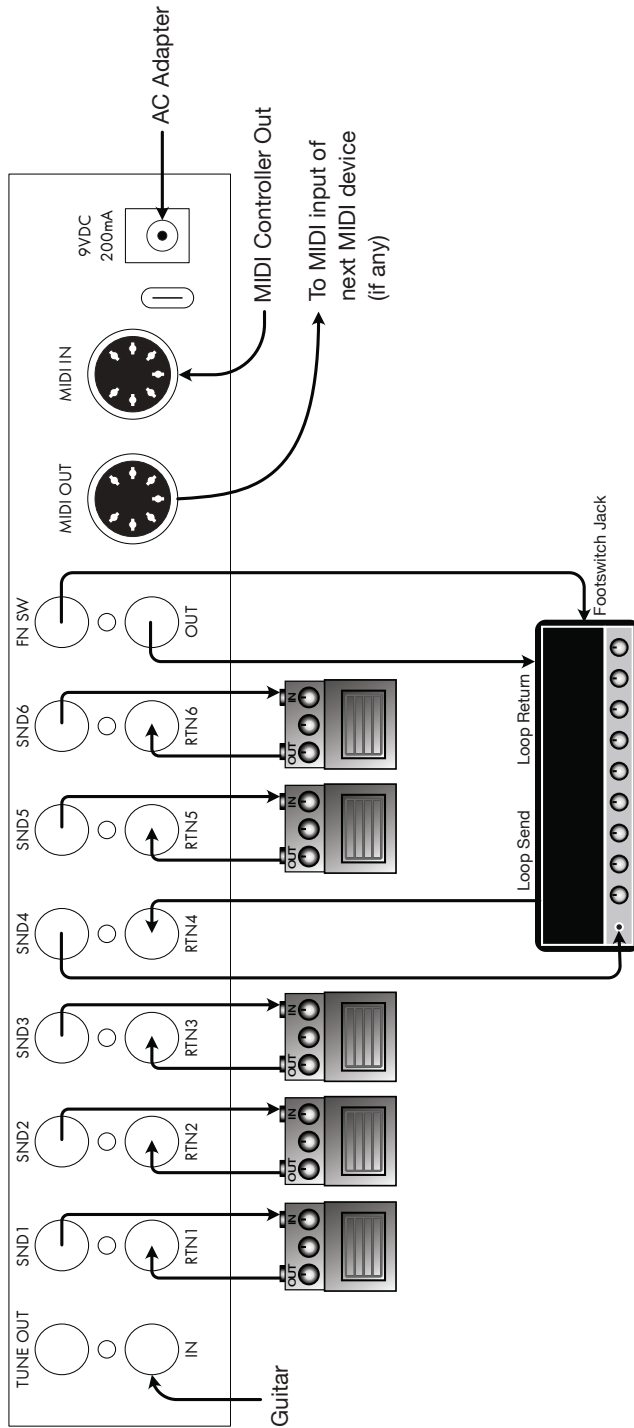

3 pedals in front, 2 in loop

This uses the "4 cable method" to connect to the amp's front input and its effect loop. Loop 4 is used as a split point and should be turned on at all times. Any pedal before loop 4 in the loop order is in front of the amp, any pedal after loop 4 is in the amp's effect loop. Function switches control channel switching on amp.



RJM Music Technology, Inc.
www.rjmmusic.com

Mini Effect Gizmo X Wiring Diagram

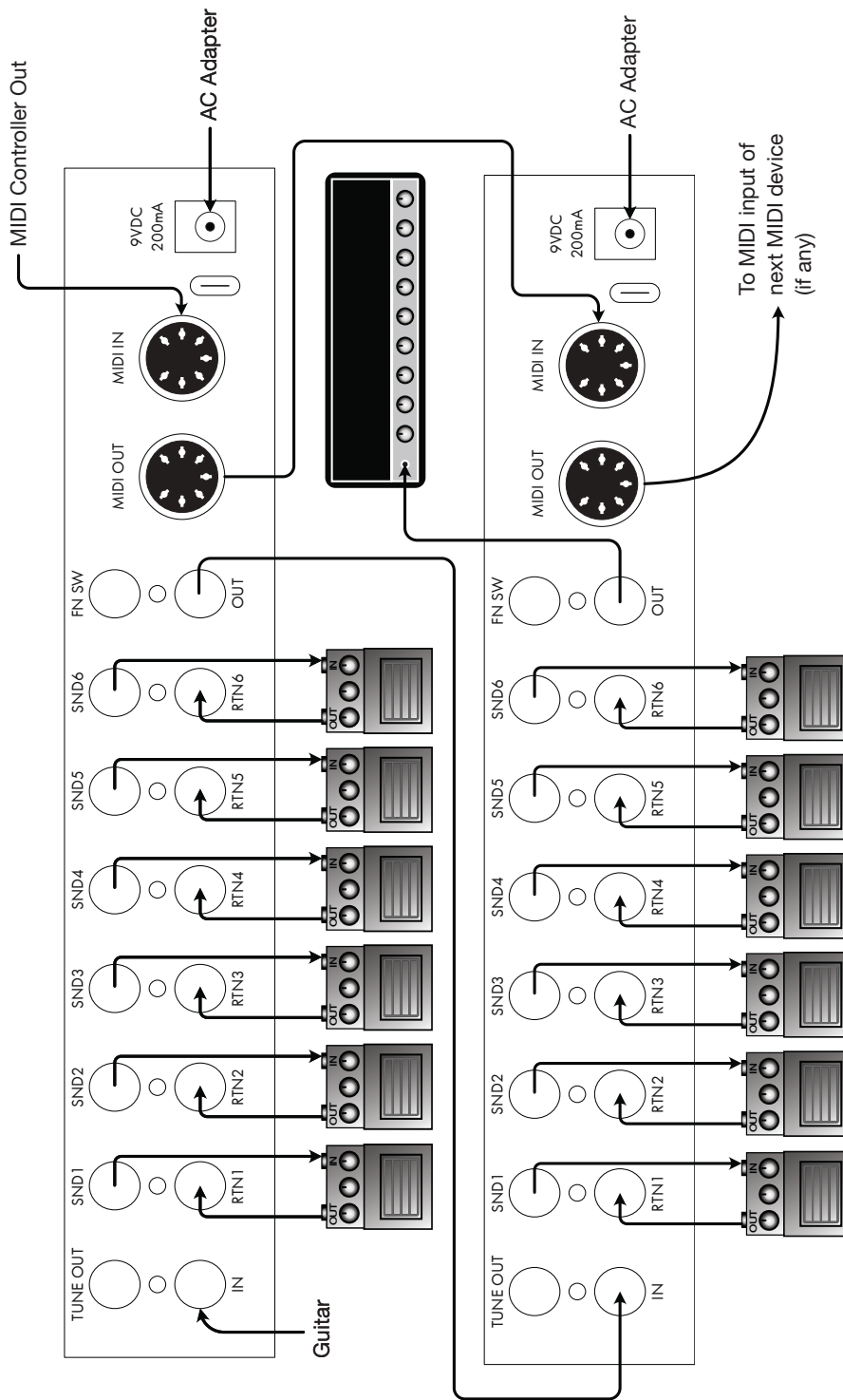

12 pedals, using two Mini Effect Gizmo Xs

12 pedals across two MEGXs, connected to the amp's front input



RJM Music Technology, Inc.
www.rjmmusic.com

Mini Effect Gizmo X Wiring Diagram

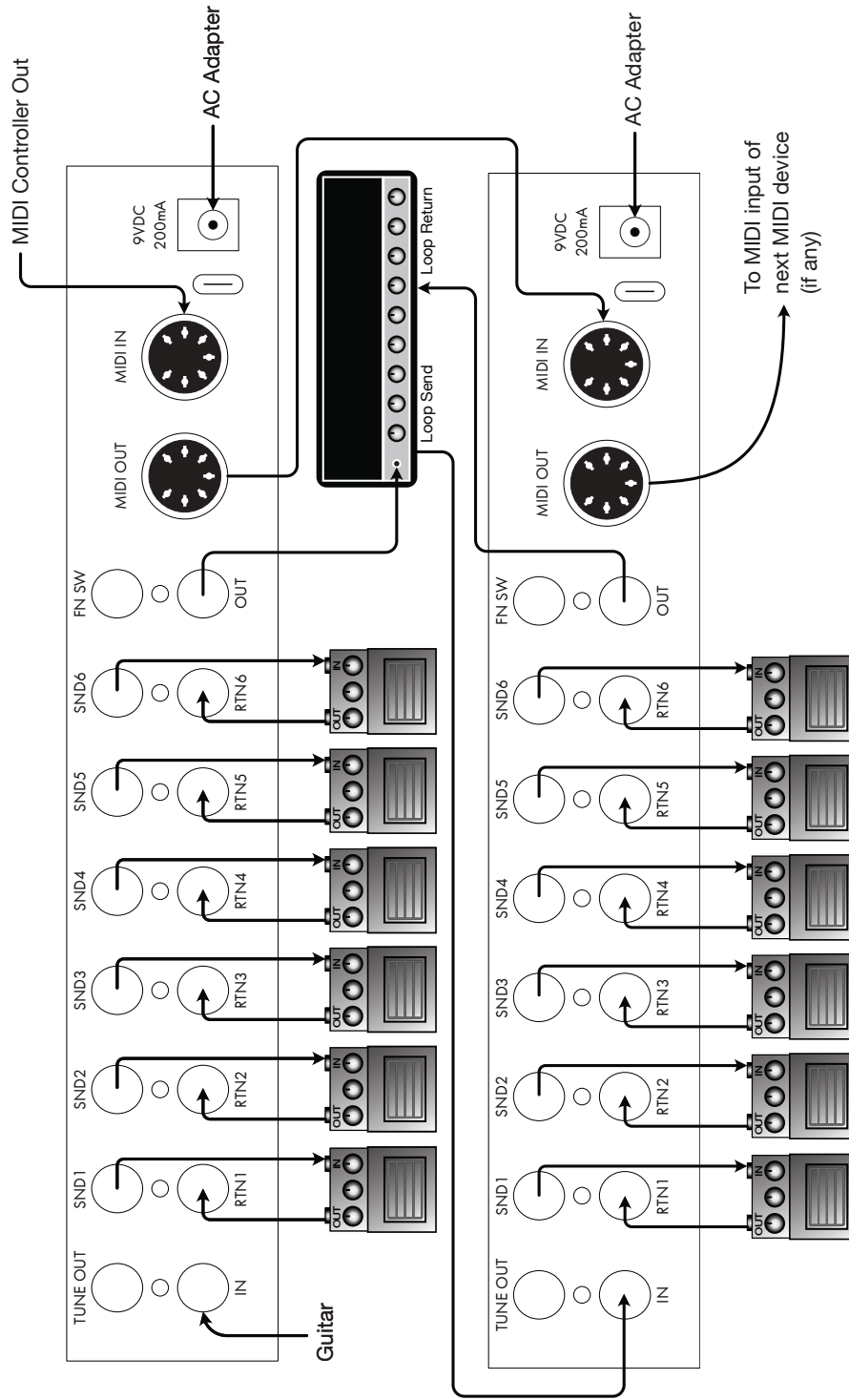

6 pedals in front, 6 in loop, using two Mini Effect Gizmo Xs
The upper MEGX's pedals are in front of the amp, the lower in the amp's effect loop.

ADVANCED FEATURE: SPLIT MONO MODE

The Mini Effect Gizmo X has the ability to split its stereo loops so that instead of left and right sides, the loops are divided into two separate mono loops. This can give you up to 12 mono loops. This is considered an advanced configuration, because it requires extra care in cabling and setup.

The Mini Effect Gizmo X editor is required to set up this feature. In the Global Settings menu, each loop has a Split Mono checkbox. Check this and it will create another loop. Turning on Split Mono for loop 1 will create loop 7, turning on Split Mono for loop 2 will create loop 8, etc. These loops will appear alongside the normal 6 loops in the loop order, preset settings page, etc. and can be configured like any other loop, except that they have to be mono.

Once a loop is configured for split mono, you need to make sure that you're using the correct cabling. You'll need two insert cables, same as with a stereo pedal. But, the connections are a bit different. This is how you would connect two pedals to the SND1 / RTN1 jack, where one pedal is in loop 1 and the other in loop 7

Each pair of pedals can be wired like this, using another pair of insert cables.

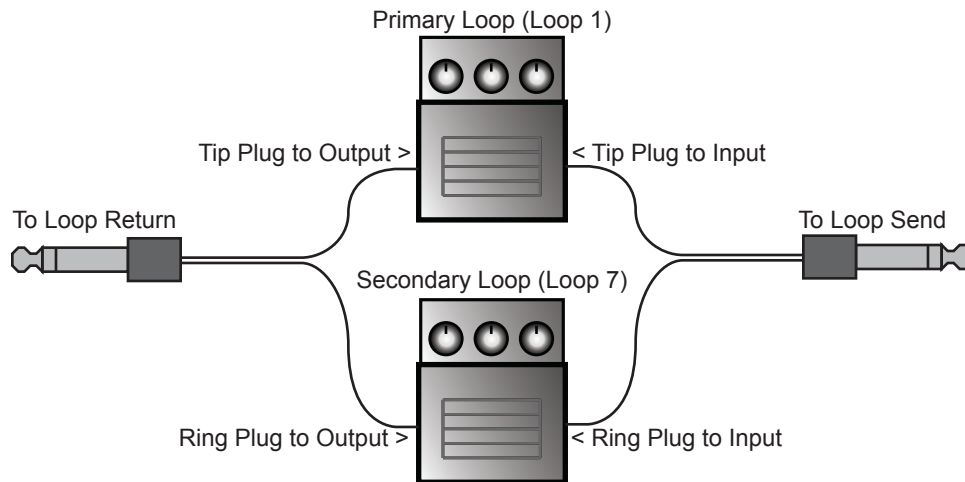

SPECIFICATIONS

Dimensions	9.25 (W) x 4 (D) x 1.7 (H) inches 23.5 (W) x 10.2 (D) x 4.3 (H) cm
Weight	1.3 lb 0.6 kg
Power	9 Volts DC or AC @ 200mA (either polarity) 5.5mm OD, 2.1mm ID x 9.5mm barrel connector (BOSS-style)
Phantom Power	9VDC, 800mA maximum current when using provided AC adaptor Provided over pins 6 and 7 of the MIDI In jack. Phantom power voltage is the same as the power provided at the Power jack. Phantom power is also passed through to pins 6 and 7 of the MIDI Out jack. Power coming out of this jack is limited to 1 Amp using a resettable fuse.
Memory	1024 programs, arranged in 8 banks of 128 Memory is non-volatile and requires no backup battery